

APPENDIX A AIR SEALING KEY POINTS

Air Barrier and Insulation Inspection Component Guide

NUMBER	COMPONENT	CRITERIA
1	Air barrier and thermal barrier	Exterior thermal envelope insulation for framed walls is installed in substantial contact and continuous alignment with building envelope air barrier. Breaks or joints in the air barrier are filled or repaired. Air-permeable insulation is not used as a sealing material. Air-permeable insulation is inside of an air barrier.
2	Ceiling/attic	Air barrier in any dropped ceiling/soffit is substantially aligned with insulation and any gaps are sealed. Attic access (except unvented attic), knee wall door, or drop down stair is sealed.
3	Walls	Corners and headers are insulated. Junction of foundation and sill plate is sealed.
4	Windows and doors	Space between window/door jambs and framing is sealed.
5	Rim joists	Rim joists are insulated and include an air barrier.
6	Floors (including above-garage and cantilevered floors)	Insulation is installed to maintain permanent contact with underside of subfloor decking. Air barrier is installed at any exposed edge of insulation.
7	Crawl space walls	Insulation is permanently attached to walls. Exposed earth in unvented crawl spaces is covered with Class I vapor retarder with overlapping joints taped.
8	Shafts, penetrations	Duct shafts, utility penetrations, knee walls and flue shafts opening to exterior or unconditioned space are sealed.
9	Narrow cavities	Batts in narrow cavities are cut to fit, or narrow cavities are filled by sprayed/blown insulation.
10	Garage separation	Air sealing is provided between the garage and conditioned spaces.
11	Recessed lighting	Recessed light fixtures are air tight, IC rated, and sealed to drywall. Exception—fixtures in conditioned space.
12	Plumbing and wiring	Insulation is placed between outside and pipes. Batt insulation is cut to fit around wiring and plumbing, or sprayed/blown insulation extends behind piping and wiring.
13	Shower/tub on exterior wall	Showers and tubs on exterior walls have insulation and an air barrier separating them from the exterior wall.
14	Electrical/phone box on exterior walls	Air barrier extends behind boxes or air sealed-type boxes are installed.
15	Common wall	Air barrier is installed in common wall between dwelling units.
16	HVAC register boots	HVAC register boots that penetrate building envelope are sealed to subfloor or drywall.
17	Fireplace	Fireplace walls include an air barrier.

Disclaimer:
This document is intended solely to help graphically demonstrate the air leakage provisions of section 402.4 of the 2009 IECC. It does not cover all airsealing locations or techniques. Other code provisions may be applicable as well.

Air sealing key points

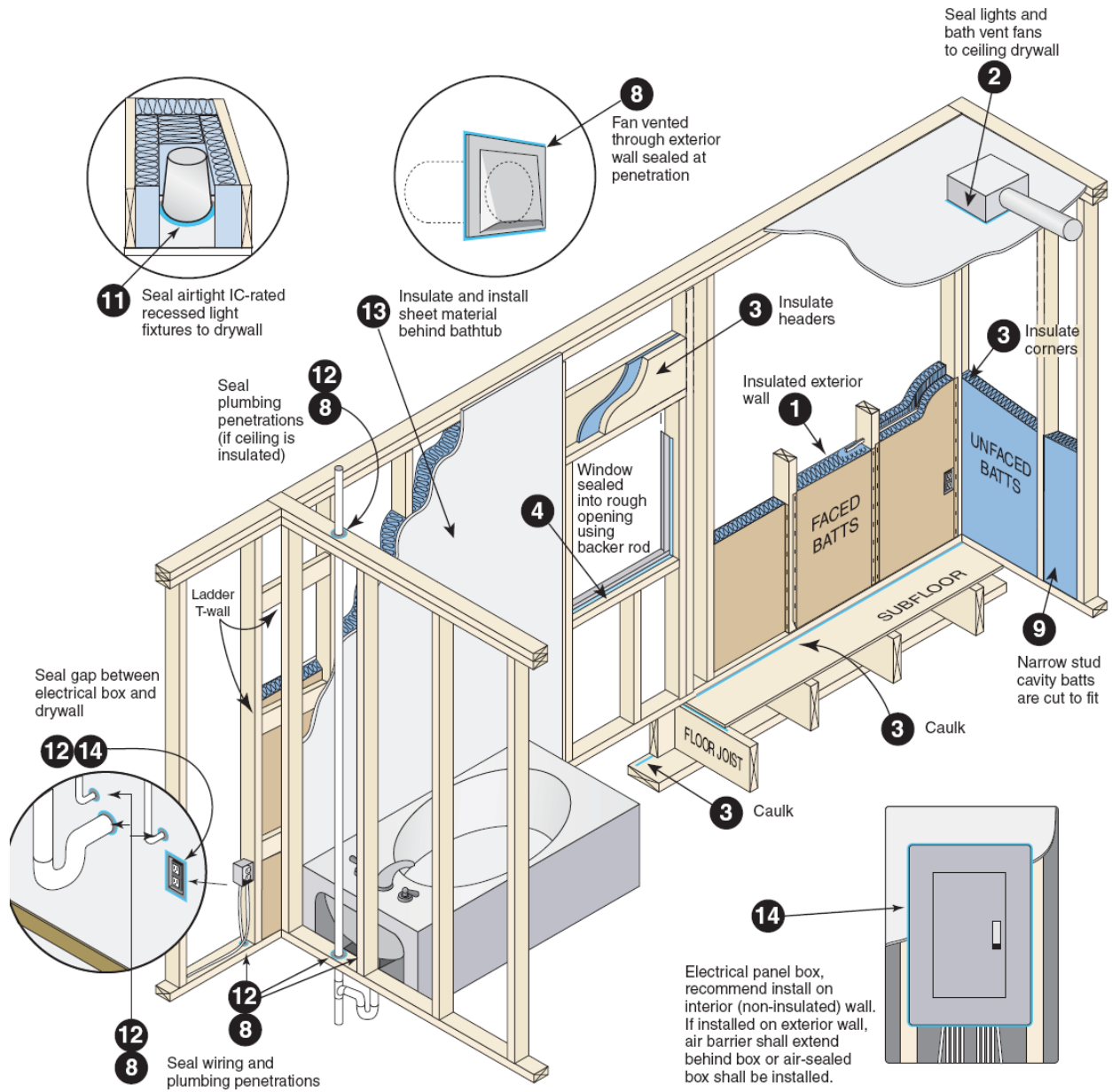

Disclaimer:
 This document is intended solely to help graphically demonstrate the air leakage provisions of section 402.4 of the 2009 IECC. It does not cover all airsealing locations or techniques. Other code provisions may be applicable as well.

Air sealing key points *continued*

Chases and common by-passes

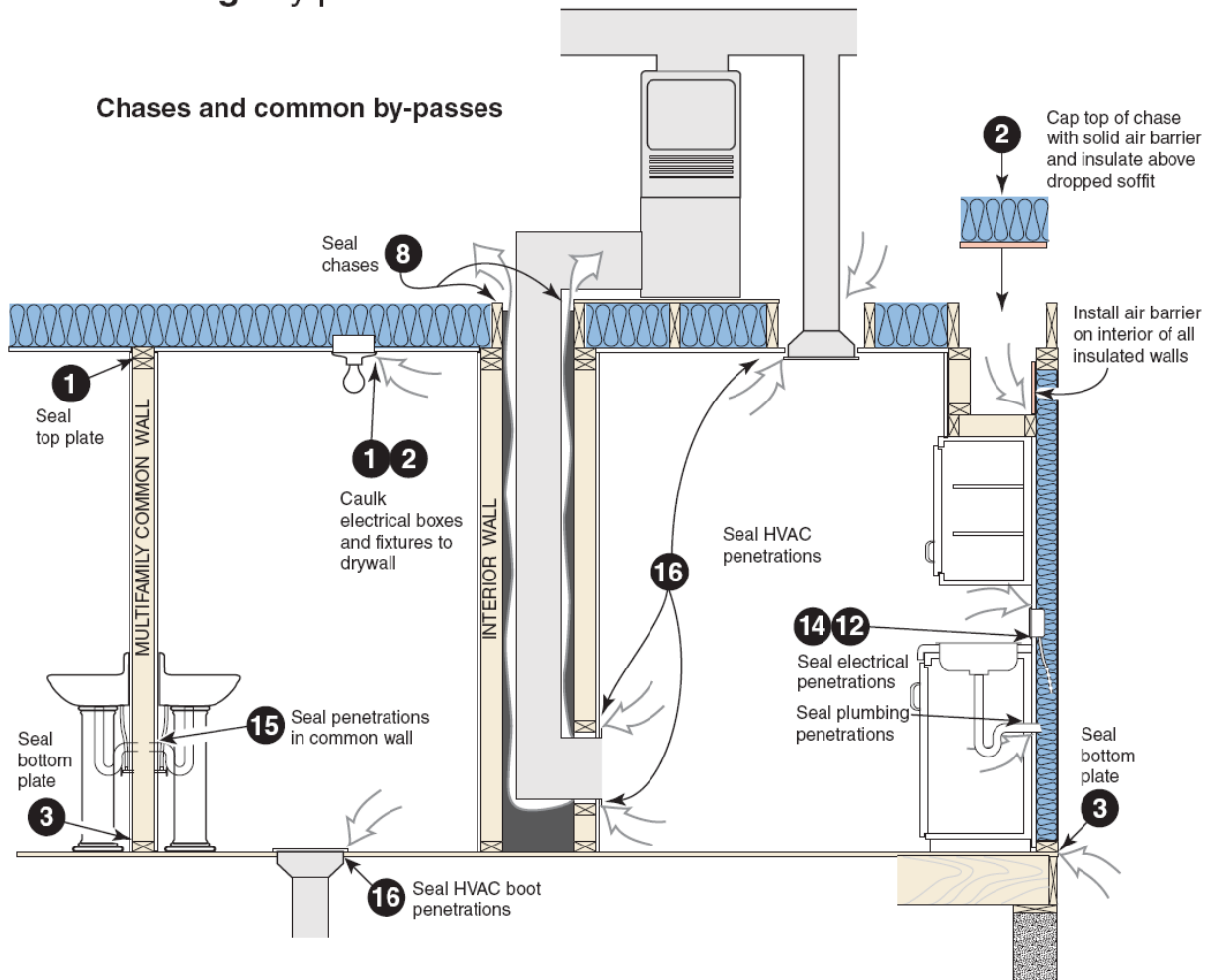

Shower/tub drain rough opening

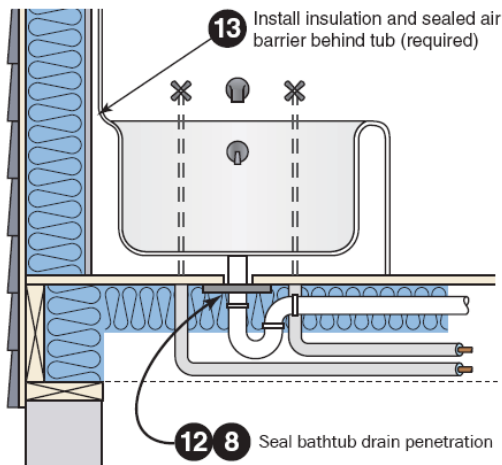

Disclaimer:
 This document is intended solely to help graphically demonstrate the air leakage provisions of section 402.4 of the 2009 IECC. It does not cover all airsealing locations or techniques. Other code provisions may be applicable as well.

Air sealing key points *continued*

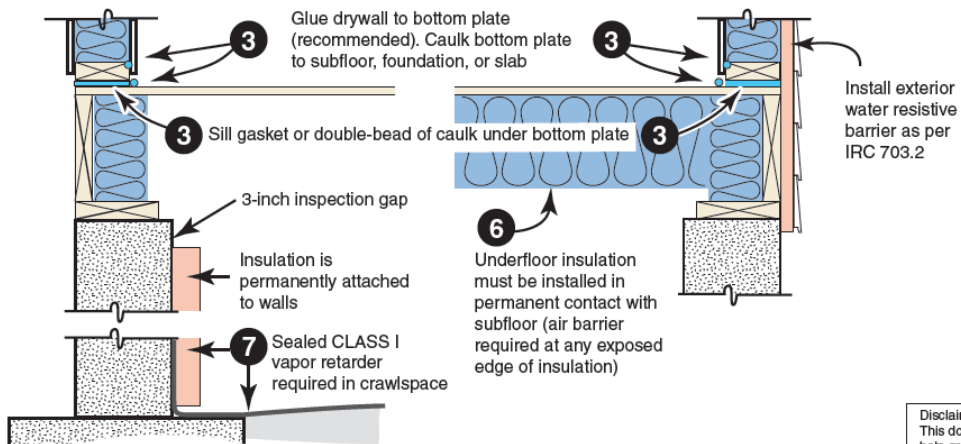
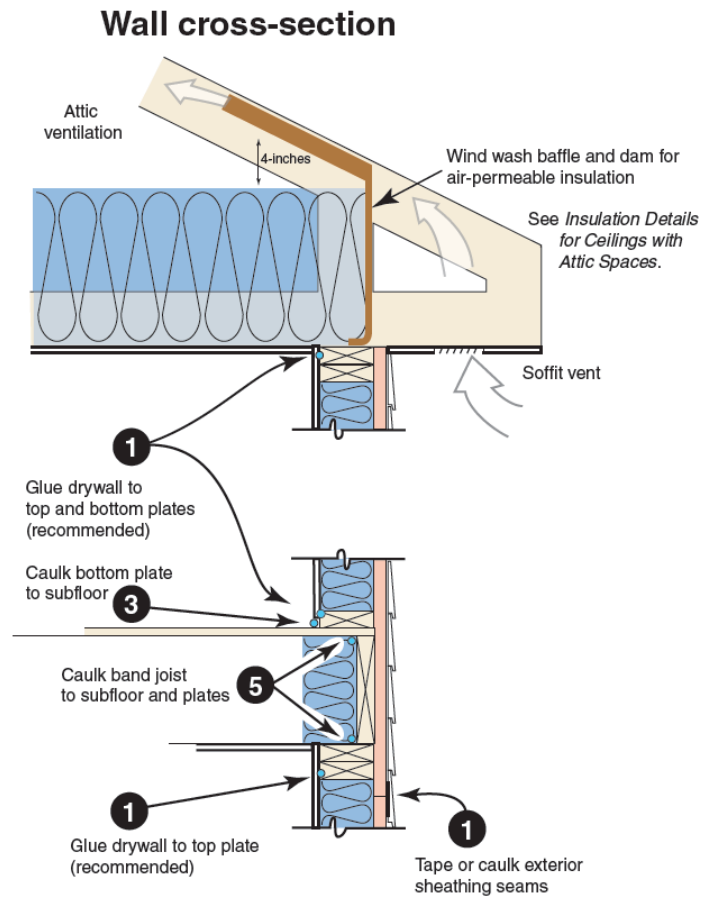
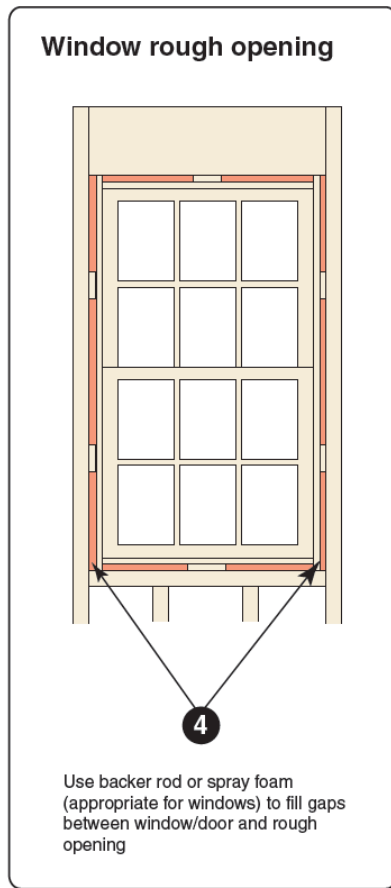

Disclaimer:
This document is intended solely to help graphically demonstrate the air leakage provisions of section 402.4 of the 2009 IECC. It does not cover all airsealing locations or techniques. Other code provisions may be applicable as well.

Air sealing key points *continued*

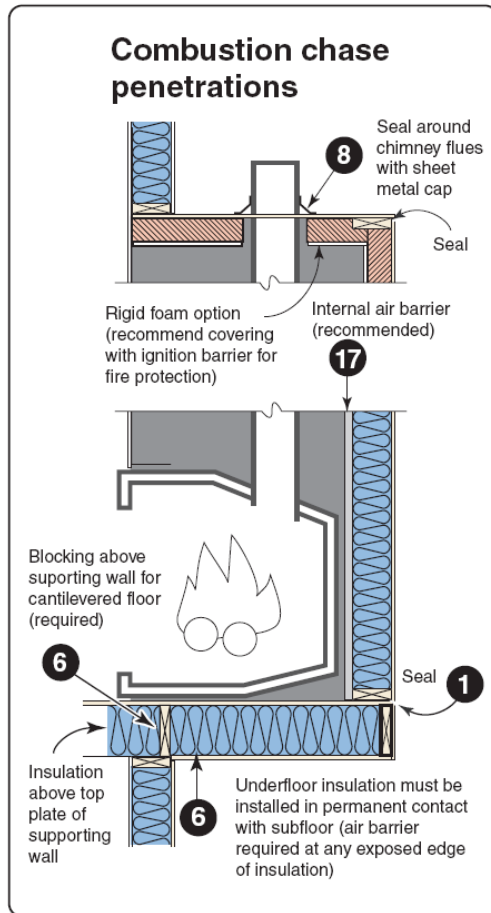

Exterior penetrations

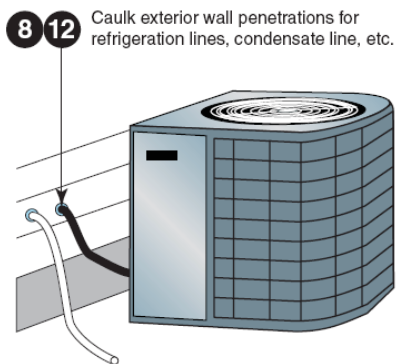

Combustion closet

Combustion air inlets
as per mechanical and/or fuel gas code

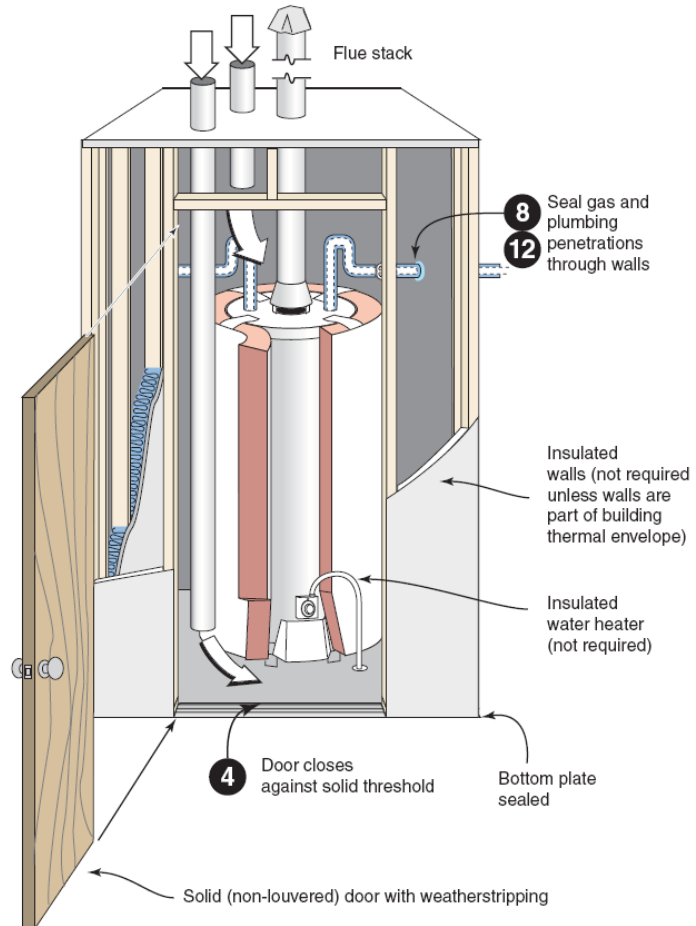

Disclaimer:
This document is intended solely to help graphically demonstrate the air leakage provisions of section 402.4 of the 2009 IECC. It does not cover all airsealing locations or techniques. Other code provisions may be applicable as well.

Air sealing key points *continued*

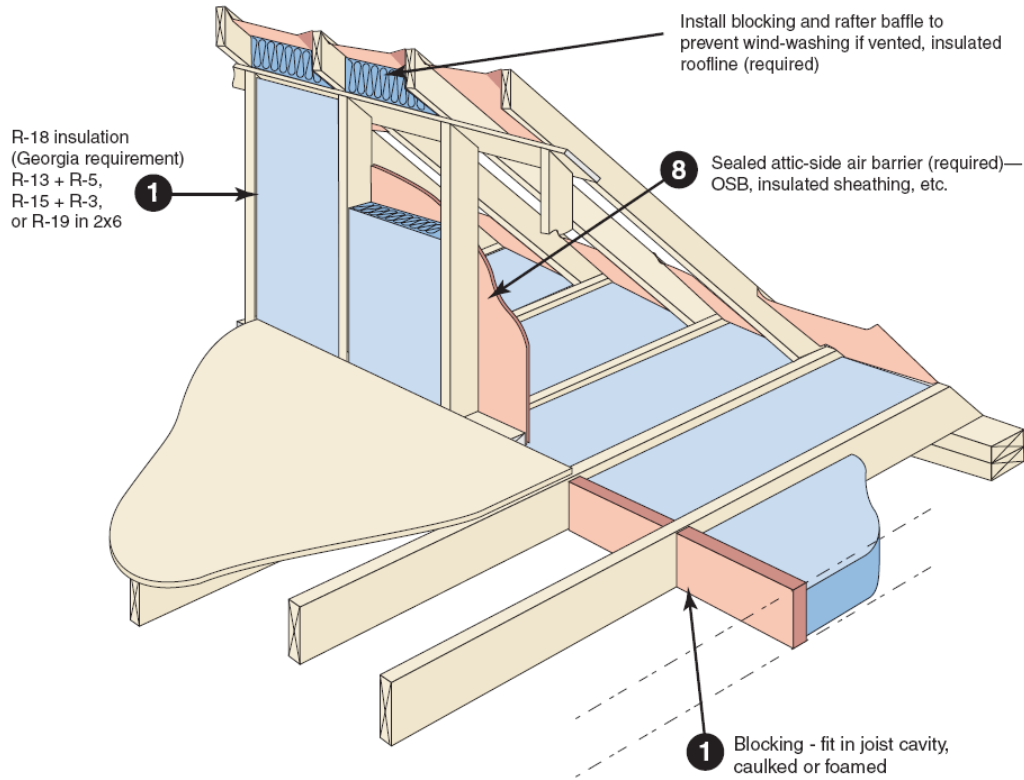

Attic knee-walls

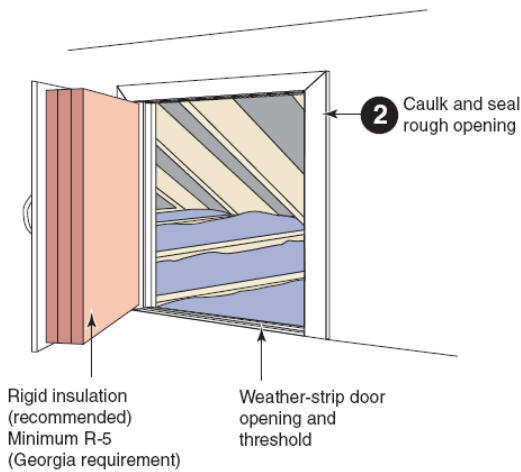

Two-level attic

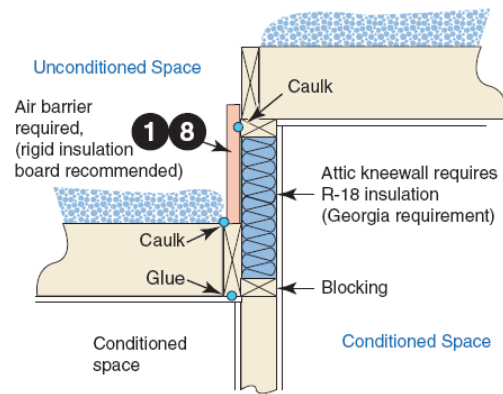

Disclaimer:
This document is intended solely to help graphically demonstrate the air leakage provisions of section 402.4 of the 2009 IECC. It does not cover all airsealing locations or techniques. Other code provisions may be applicable as well.

Air sealing key points *continued*

Attic scuttle

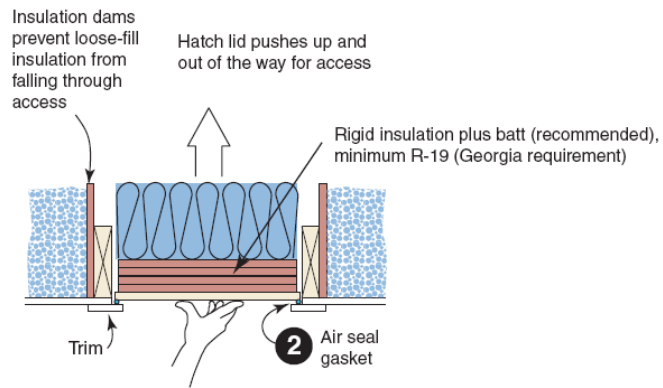

Attic pull-down stairs

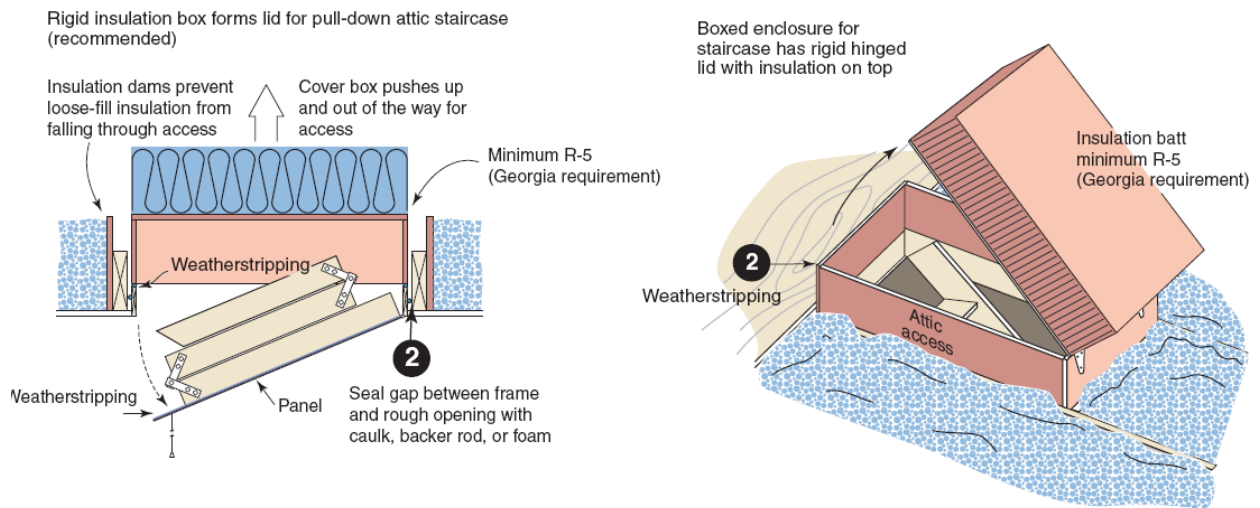

Attic pull-down stairs

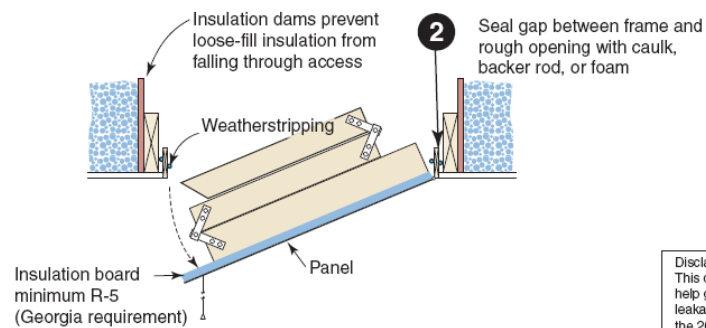

Disclaimer:
This document is intended solely to help graphically demonstrate the air leakage provisions of section 402.4 of the 2009 IECC. It does not cover all airsealing locations or techniques. Other code provisions may be applicable as well.

Air sealing key points *continued*

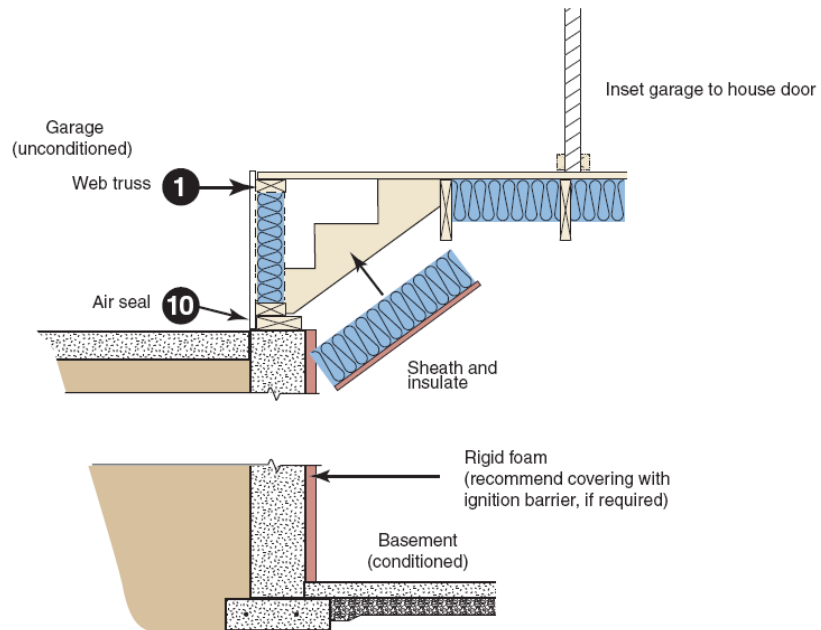
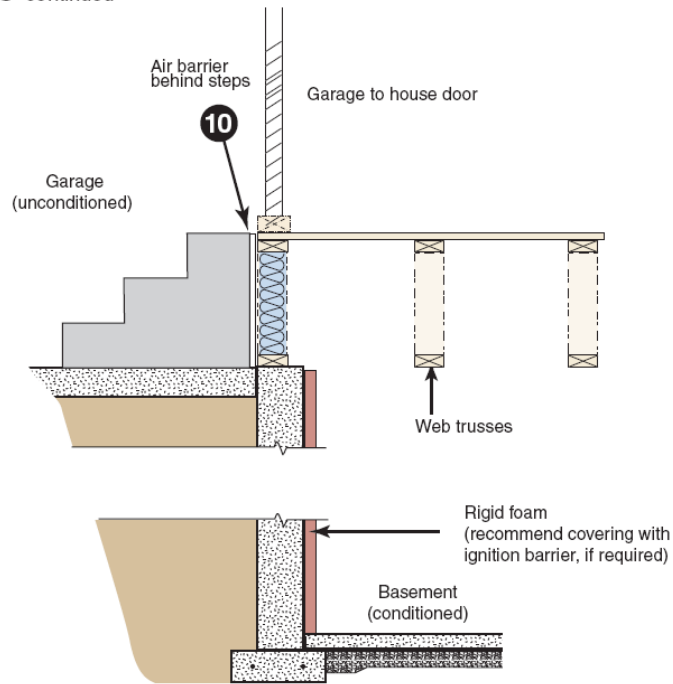

Disclaimer:
 This document is intended solely to help graphically demonstrate the air leakage provisions of section 402.4 of the 2009 IECC. It does not cover all airsealing locations or techniques. Other code provisions may be applicable as well.

Air sealing key points *continued*

Multifamily

Additional Multifamily Air-sealing Keypoints

1. Cap and seal all chases including chases for grouped utility lines and radon vents
2. Seal penetrations in mechanical closet including penetrations for the:
 - a. supply plenum
 - b. outside air ventilation
 - c. refrigerant line
 - d. plumbing
 - e. electrical
 - f. gas fuel
3. Seal band area at exterior sheathing side and all penetrations through band
4. Air seal at drywall finishing for any wall adjacent to stairwell or elevator. Air seal this gap at every change in floor level
5. Seal miscellaneous clustered penetrations through building envelope (e.g. refrigerant lines)

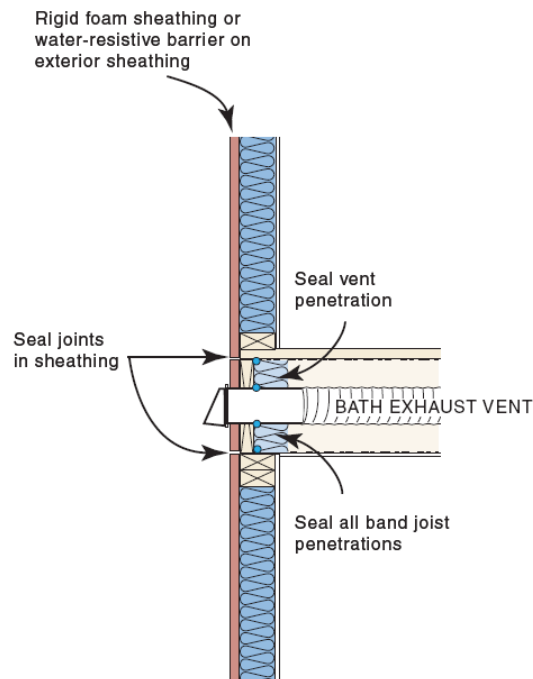

Disclaimer:
This document is intended solely to help graphically demonstrate the air leakage provisions of section 402.4 of the 2009 IECC. It does not cover all airsealing locations or techniques. Other code provisions may be applicable as well.

Air sealing key points *continued*

Mechanical Closet

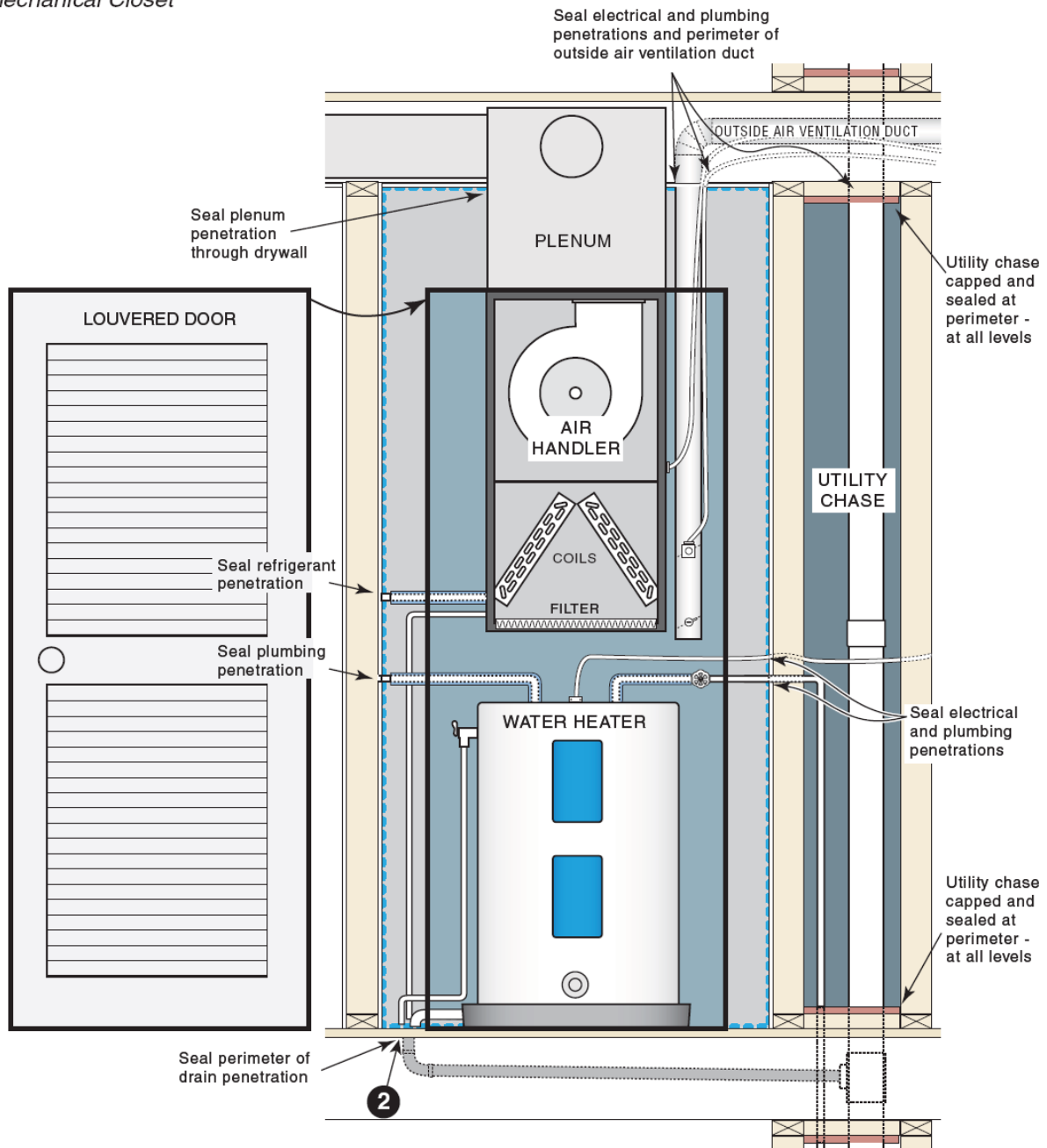

Disclaimer:
This document is intended solely to help graphically demonstrate the air leakage provisions of section 402.4 of the 2009 IECC. It does not cover all airsealing locations or techniques. Other code provisions may be applicable as well.

Air sealing key points *continued*
Multifamily

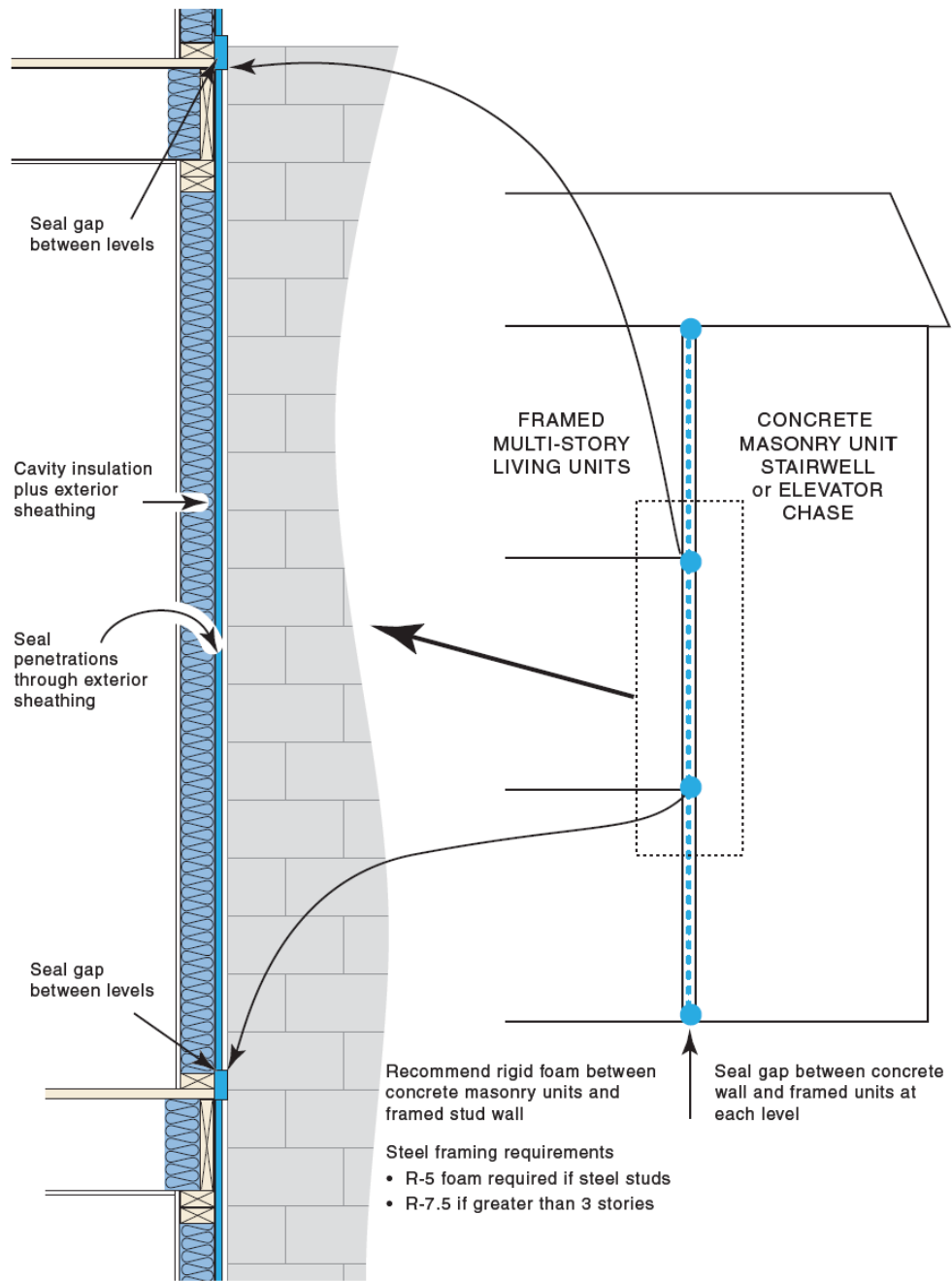

Disclaimer:
 This document is intended solely to help graphically demonstrate the air leakage provisions of section 402.4 of the 2009 IECC. It does not cover all airsealing locations or techniques. Other code provisions may be applicable as well.

Building Thermal Envelope — The basement walls, exterior walls, floor, roof, and any other building element that enclose conditioned space. This boundary also includes the boundary between conditioned space and any exempt or unconditioned space. —2009 IECC

The *building thermal envelope* is the barrier that separates the conditioned space from the outside or unconditioned spaces. The building envelope consists of two parts - an air barrier and a thermal barrier that must be both continuous and contiguous (touching each other). In a typical residence, the building envelope consists of the roof, walls, windows, doors, and foundation. Examples of unconditioned spaces include attics, vented crawlspaces, garages, and basements with ceiling insulation and no HVAC supply registers.

Example 1

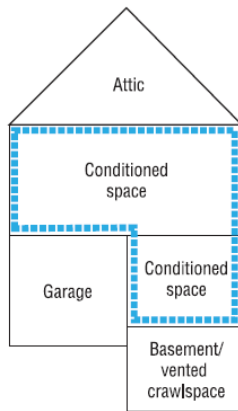

This is a conventional approach that likely locates all ductwork in unconditioned spaces.

Example R-values¹

- Flat ceiling: R-30
- Exterior walls: R-13 + R-3 sheathing
- Floor over garage and basement/crawl: R-19
- Ductwork sealed with mastic and insulated to R-8 in attic, R-6 in basement/crawlspace
- Garage⁵, attic and basement/crawl are unconditioned spaces

Example 2

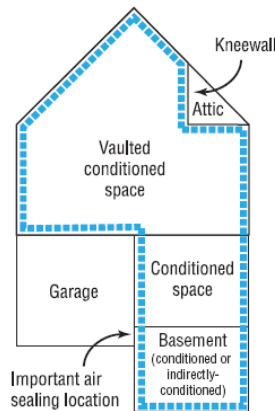

If supply registers deliver conditioned air to basement, it is considered conditioned. With no supply air, it is considered an indirectly-conditioned space.

Example R-values¹

- Flat ceiling: R-38
- Kneewalls²: R-18 (required) (R-13+ R-5, R-15 + R-3, R-19 in 2x6)
- Vaulted ceiling³: R-19 air-permeable insulation plus R-5 rigid foam board
- Exterior walls: R-13
- Basement masonry walls: R-5
- Basement slab⁴: R-0
- Ductwork sealed with mastic and insulated to R-8 in attic, R-6 in basement
- Garage⁵ and attic are unconditioned spaces

Example 3

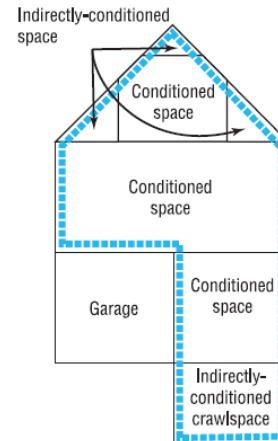

The top conditioned floor functions as a vaulted ceiling with interior walls although it appears to have kneewalls and a flat ceiling. An advantage of this approach is that all upstairs ductwork is located inside the building envelope.

The crawlspace walls are insulated and do not contain vents. The crawlspace ground is covered with concrete or 100% plastic and functions as a "mini-basement."

Example R-values¹

- Vaulted ceiling³: R-19 air-impermeable foam insulation
- Exterior walls: R-13 + R-3 sheathing
- Crawlspace walls: R-5
- Ductwork sealed with mastic and insulated to R-6
- Garage⁵ is unconditioned space

1 R-values shown are examples and not code requirements. Refer to table 402.1.1 for specific prescriptive insulation requirements.

2 An *attic kneewall* is any vertical wall that separates conditioned space from an unconditioned attic. In Georgia, kneewalls must be insulated to R-18. A sealed attic-side air barrier (OSB, foil-faced sheathing, etc.) is required when using air permeable insulation.

3 Requires trade-off (such as REScheck) since prescriptive ceiling requirement is R-30 / R-38, see roofline installed insulation options and section 806.4 of the 2006 IRC.

4 Slab Insulation is not required in Georgia due to termite risk.

5 Although there is nothing to prevent the garage walls from being insulated, due to indoor air quality concerns, the garage should never be considered inside the building envelope.

Insulation Details for Ceilings with Attic spaces

Rafter and Truss

Standard Truss with tapered insulation depth

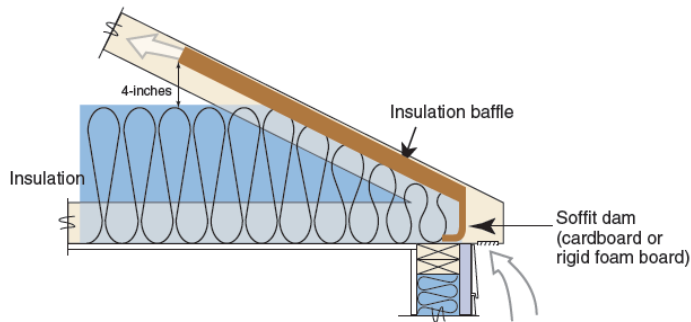

Energy Truss with full height insulation (recommended)

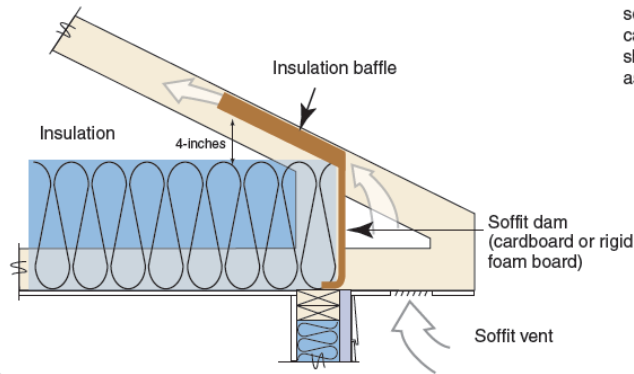

Standard rafter and top plate with tapered insulation depth

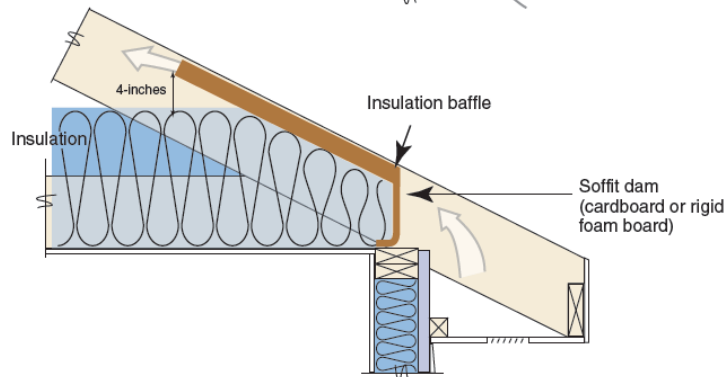

Rafter on raised top plate with full height insulation (recommended)

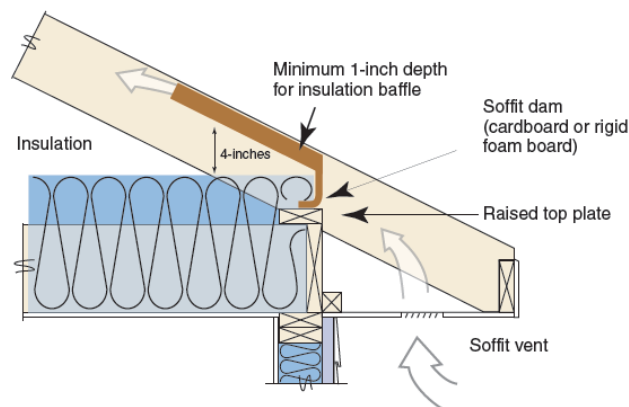

Note: Wind wash baffle and air-permeable insulation dam. For air permeable insulation in vented attics, baffles shall be installed adjacent to soffit and eave vents. A minimum of a 1-inch of space shall be provided between the insulation and the roof sheathing and at the location of the vent. The baffle shall extend over the top of the insulation inward until it is at least 4 inches vertically above the top of the insulation. Any solid material such as cardboard or thin insulating sheathing shall be permissible as the baffle.

Disclaimer:
This document is intended solely to help graphically demonstrate the air leakage provisions of section 402.4 of the 2009 IECC. It does not cover all airsealing locations or techniques. Other code provisions may be applicable as well.

Roofline Installed Insulation Options

Reference Table 402.1.4 in Georgia amendments to the 2009 IECC and Section 806.4 "unvented attic assemblies" in the Georgia Amendments to the 2006 IRC

Air impermeable installed insulation
(e.g., spray foam insulation)

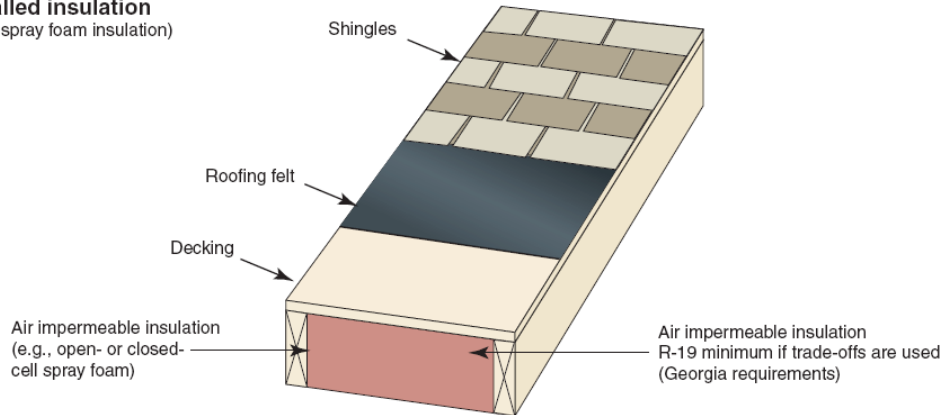

Air-permeable installed insulation
(e.g., fiberglass, cellulose)

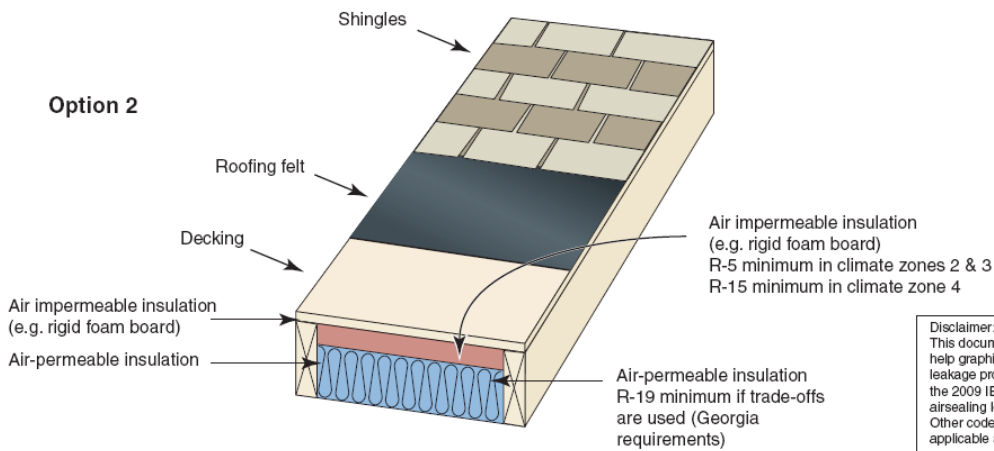
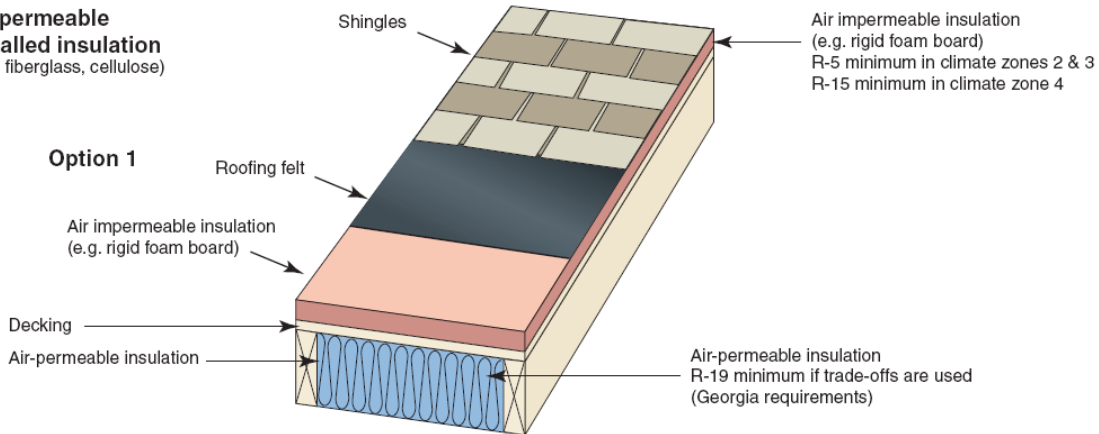

Disclaimer:
This document is intended solely to help graphically demonstrate the air leakage provisions of section 402.4 of the 2009 IECC. It does not cover all airsealing locations or techniques. Other code provisions may be applicable as well.